

# High Precision Tool Grinding Spindle Motor CHCNC2000 - 70 - 202

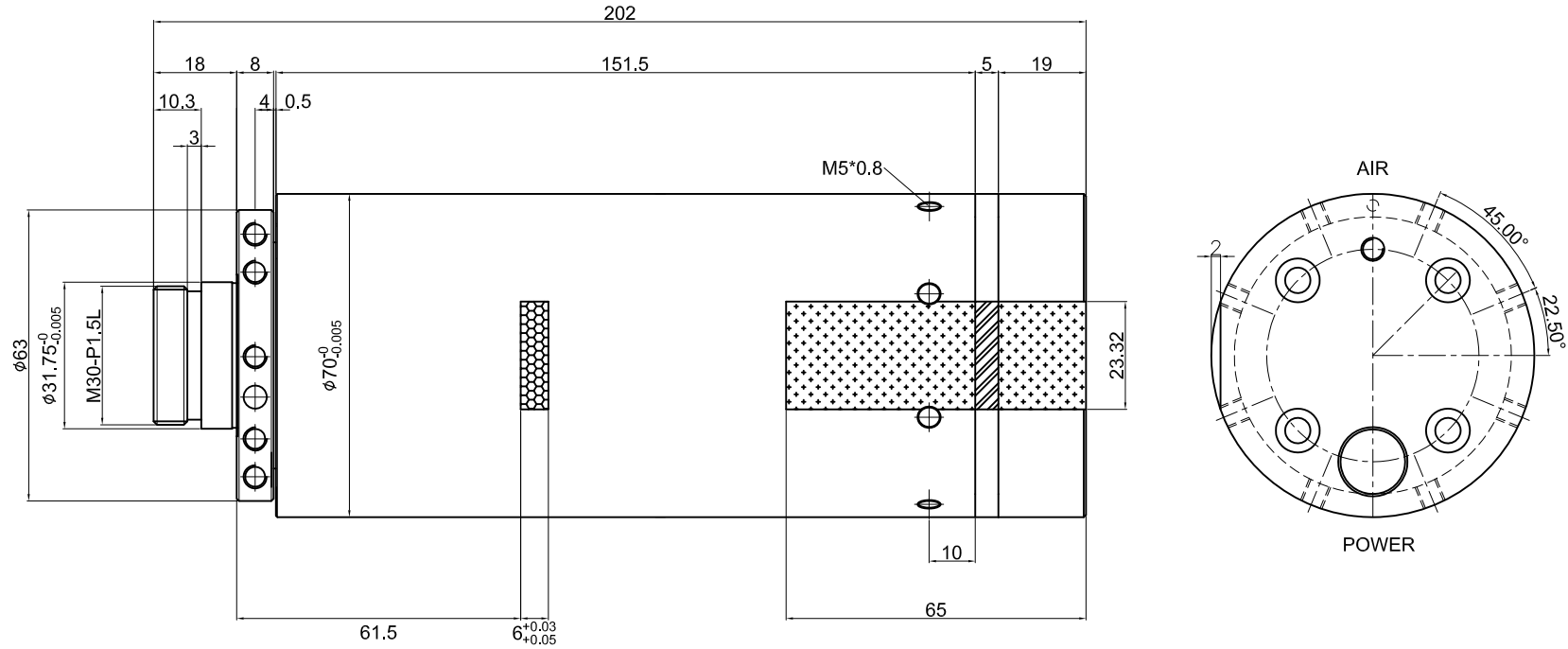

Motor Pole : 4 P  
Motor Power : 1.5 Kw  
Motor Voltage : 200 V  
Motor Frequency : 147 Hz  
Motor Rated Speed : 4500 rpm.  
Motor Max. Speed : 12000 rpm.  
Spindle Run Out : 0.002 mm